

**PROPOSAL FOR  
LELAND DAM PEDESTRIAN BRIDGE SURFACE  
AND RAILING REPLACEMENT PROJECT**

**REQUEST FOR PROPOSALS LCAO-RFP-2024-007**



**Proposals Due  
September 24, 2024  
3:00 p.m.**

**SUBMIT PROPOSALS TO:**

**COUNTY OF LEELANAU  
ADMINISTRATOR'S OFFICE  
8527 E. GOVERNMENT CENTER DR., SUITE #101  
SUTTONS BAY, MICHIGAN 49682**

**PHONE (866) 256-9711      FAX (231) 256-0120**

## INSTRUCTIONS AND INFORMATION

Read all documents contained in the proposal specifications.

### 1.0 INTRODUCTION

#### 1.01 PURPOSE

The County of Leelanau (hereinafter referred to as the “County”) solicits proposals from interested, experienced, and qualified vendors for demolition and replacement of the Leland Dam Pedestrian Bridge surface and railing, located at 109 W River St, Leland, MI 49654, as assigned by the County Administrator.

#### 1.02 REGISTRATION WITH THE COUNTY

Vendors submitting a proposal to the County must follow these three (3) steps:

1.02.1 Register as a vendor with the County by means of this link: <http://bidnetdirect.com>. After completing a brief company profile, you shall be asked to categorize the product(s) and/or services you provide. Completing this registration will add you to the County’s vendor database.

1.02.2 If already registered, review your on-line profile and revise to insert current information.

### 2.0 PROPOSAL SUBMISSION

The County’s official proposal documents can be obtained from the Michigan Inter-governmental Trade Network at <http://bidnetdirect.com> or, if applicable, the Leelanau County Administrator’s Office. Copies of proposal documents obtained from any other source are not considered official copies. In addition to obtaining the official proposal documents, any and all addenda pertaining to a particular proposal are posted on the same website that the official proposal documents are obtained: <http://bidnetdirect.com>. It is incumbent upon all potential Proposers to view all posted addenda prior to the proposal close date. If you have obtained this document from a source other than the Leelanau County Administrator’s Office or the Michigan Inter-governmental Trade Network, it is recommended that you obtain an official copy. You may obtain an official copy by registering on the Michigan Inter-governmental Trade Network at <http://bidnetdirect.com>.

Proposals must be submitted in complete original form by mail or by messenger in a sealed envelope/package to the following address:

**OFFICE OF THE COUNTY ADMINISTRATOR**  
LEELANAU COUNTY GOVERNMENT CENTER  
8527 E. Government Center Dr., Suite #101  
Suttons Bay, Michigan 49682

All proposals received shall be notated as such on the outside of the envelope:

PROPOSAL: **PROPOSAL FOR LELAND DAM PEDESTRIAN BRIDGE SURFACE AND RAILING REPLACEMENT PROJECT – LCAO-RFP-2024-007**

DUE DATE: **September 24, 2024, at 3:00 P.M. (Local Time)**

COMPANY NAME:

Any questions with regard to the specifications of the proposal should be directed via email to Leelanau County Administration at [lcypher@leelanau.gov](mailto:lcypher@leelanau.gov).

Proposers are responsible for submitting their proposals to the appropriate location at or prior to the time indicated in this Request for Proposals (hereinafter referred to as the "RFP"). **No proposals will be accepted after the designated time or date indicated in this RFP.** It is recommended that proposals be submitted in advance, at least one (1) day prior to the specified date and time to allow for a timely receipt. Delay in mail delivery is not an exception to the receipt of a proposal.

Failure to follow the instructions for the submission of a proposal may result in rejection of the proposal as being unresponsive.

The following forms are necessary to be submitted as a proposal, as well as any additional forms requested in the detailed specifications:

1. **CS-1 - Proposal form/price pages(s)** (Note: some proposals may include a separate Bid Proposal Form. Such exceptions will be noted in the proposal specification).
2. **CS-2 - Non-Collusion Affidavit**, completed, signed and dated.

Proposers must submit in a sealed envelope **one (1) original, plus one (1) copy** of their proposal, **unless otherwise stated in the specifications.** The original **must be clearly marked.** All proposals must be filled out in black ink or be typewritten. Proposals submitted in pencil will be rejected as unresponsive. Proposals which have been corrected by whiteout or cross out, and have not been initialed and/or dated, will be rejected as unresponsive.

Should the Proposer find discrepancies or omissions in the specifications, he/she shall notify the Leelanau County Administrator's Office at once. The County will not assume responsibility for any oral instructions or interpretations of meaning of the specifications or other contract documents to any Proposer by any person or persons.

The Leelanau County Administrator, and/or his/her designee, shall be the only one authorized to make changes or alterations to anything contained in these specifications. Such changes shall be posted as an addendum on the following website: <http://bidnetdirect.com>.

Written questions and inquiries concerning this RFP shall be submitted to Lauren Cypher at [lcypher@leelanau.gov](mailto:lcypher@leelanau.gov) **on or before the date and time stated in the RFP documents. Verbal questions will not be entertained.**

### 3.0 RESERVATION OF RIGHTS

The County reserves the right to reject any and all proposals; to award the contract to other than the lowest proposal; to award separate contracts for separate parts of the services required; to negotiate the terms and conditions of all and any part of the proposal(s); to waive irregularities and/or formalities; and, in general, to make award in the manner as determined by the Leelanau County Board of Commissioners, in its sole discretion, to be in the County's best interest.

#### 4.0 CONTRACT AWARD

The contract will be awarded to the **RESPONSIBLE PROPOSER** best meeting the needs of the County, based on, but not limited to:

- 4.01 Approach to the project.
- 4.02 Experience in meeting the needs of the project (examples should be submitted with the proposal).
- 4.03 Experience working with other entities (references must include client name, contact person, phone number and description of project and shall be set forth on Attachment A – Contractor’s Qualification Statement).
- 4.04 Ability to provide services in a timely manner, meeting established project deadlines, including a strategy of key activities and ability to meet target schedule.
- 4.05 Proposed cost.

The County shall also consider who has demonstrated judgment and integrity, is of good reputation, experienced in his/her/its work, whose record of past performance in the trade is established as satisfactory, and whose financial status is such to provide no risk to the County in its contractual relations.

Upon acceptance of any proposal, the successful Proposer shall execute a contract similar to the model Agreement Document, Attachment B of this RFP, with the County of Leelanau, State of Michigan.

A contract shall not be assignable by the Contractor in whole or in part without the written consent of the County.

#### 5.0 GRIEVANCE AND PROTEST PROCEDURES:

- 5.01 Any protest to the Leelanau County Administrator’s consideration of any proposal must be submitted in writing and received by the Leelanau County Administrator no later than five (5) calendar days after the contract award. A written reply to the protest will be sent to the protesting Proposer by the Leelanau County Administrator.
- 5.02 The protest must contain:
  - 5.02.1 Identification of the statute or procedure that is alleged to have been violated;
  - 5.02.2 A precise statement of the relevant facts;
  - 5.02.3 Identification of the issues to be resolved;
  - 5.02.4 Aggrieved party’s argument and supporting documentation.

**Any notice of protest received after the deadline will not be considered.**

**NOTE: VARIATIONS AS STATED IN THE PROJECT’S SPECIFICATIONS TAKE PRECEDENCE OVER THESE INSTRUCTIONS AND INFORMATION SECTION.**

**LELAND DAM PEDESTRIAN BRIDGE SURFACE  
AND RAILING REPLACEMENT PROJECT  
SPECIFICATIONS**

**1.0 GENERAL INFORMATION**

- 1.01 Proposals are requested from contractors for the demolition and replacement of Leland Dam Pedestrian Bridge floor surfaces and railings. Project specifications are supplied on the construction documents included in the bid package. Contractors are to familiarize themselves with the plans and specifications along with completion of a site visit prior to bidding.
- 1.02 Primary interface between the awarded vendor and Leelanau County will be through the Leelanau County Administrator's Office. The Administrator will be responsible for the coordination of the awarded vendor's work.
- 1.03 **Manufacturer's Warranty:** Materials furnished by the successful Proposer shall be accompanied by the manufacturer's written warranty against defects in quality, craftsmanship, and materials. The Proposer agrees that the items of tangible personal property, services or construction furnished under any contract resulting from this bid shall be covered by the most favorable commercial warranties the Proposer gives to any customer for such items. Further, the bidder agrees that the rights and remedies provided in such warranties extend to the County and are in addition to and do not limit any rights afforded to the County by any other clause of this bid. The bidder agrees not to disclaim warranties of fitness for a particular purpose of merchantability. Warranties shall become effective at the time of acceptance.
- 1.04 The Proposer shall comply with all Federal, State and Local Laws, regulatory requirements, codes, and recommended industry practices.
- 1.05 Proposer will be required to provide copies of all certifications, notifications, permits, and other documentation as required in this section and throughout this RFP document to the County Administrator prior to and during project implementation as applicable.

**2.0 SCOPE OF SERVICES**

- 2.01 The Proposer will have the ability to perform deck and railing demolition and replacement services as set forth in Scope of Work Item Descriptions attached as Attachment C. Work will be scheduled and arranged with local businesses to not impede on access for travel to and from local businesses. The successful bidder is responsible for physically reviewing the work prior to providing a bid.

**3.0 QUALIFICATIONS & EXPERIENCE**

- 3.01 **Proposer's Personnel:**
  - 3.01.1 The awarded vendor shall provide only full time, qualified and trained personnel to perform the work that is subject to this contract.
- 3.02 **Proposer's Work Experience and References:**
  - 3.02.1 Proposers must have been in a business performing the work outlined in these specifications for a minimum of five (5) years.

**4.0 PROPOSAL SUBMISSION**

Responses to this RFP must include the following:

- 4.01 Proposer shall provide a minimum of three (3) customer references.
- 4.02 A statement of your company's proposed handling of the project's scope of work.
- 4.03 Documentation demonstrating five (5) years of experience in the type of work outlined in the Scope of Services.
- 4.04 A current resume for all persons who would be working on the project which includes a description of qualifications, skills and current availability. It should also demonstrate each person's role in the project. At minimum, resumes for the project manager must be included.
- 4.05 Proposers shall provide a completed Qualification Statement with their proposal. See Attachment "A", Qualification Statement.
- 4.06 Proposer shall describe the proposed strategy and/or plan for achieving the objectives of the RFP. Proposer may utilize a written narrative or any other printed technique to demonstrate the ability to satisfy the scope of services. The narrative should describe a logical progression of tasks and efforts starting with the initial steps or tasks to be accomplished and continuing until all proposed tasks are fully described and the RFP objectives and deliverables are accomplished.
- 4.07 Proposal shall include a detailed time schedule for completion of the project.

**5.0 FEE PROPOSAL TO THE COUNTY**

- 5.01 Proposers are to provide the County with the proposed cost Proposer will bill the County for the performance of the work required by this RFP.

**6.0 EVALUATION PROCESS**

- 6.01 Proposals submitted will be evaluated by a review committee. The review committee shall review and evaluate each of the proposals using the criteria described below under Section 7.0 Proposal Evaluation Criteria. Each reviewer will rank each proposal according to the Criteria. The reviewers will then convene to review and discuss these evaluations.
- 6.02 The County reserves the right to seek clarification of information submitted in response to this RFP and/or request additional information during the evaluation process.

**7.0 PROPOSAL EVALUATION CRITERIA**

- 7.01 Proposals will be screened for completeness and compliance with Section 3.0 Qualifications and Experience and Section 4.0 Proposal Submission.
- 7.02 Every proposal submitted will be reviewed in accordance with the following criteria:
  - 7.02.1 Experience and Qualifications
  - 7.02.2 Proposer's plan to complete the project as outlined in the scope of work

**8.0 ON-SITE VISIT**

- 8.01 Proposers are **required** to schedule a walk-through appointment with the Maintenance Director. This is a mandatory component of the RFP process. Call the Leelanau County Administrator's Office at 231-256-

9711 or email [lcypher@leelanau.gov](mailto:lcypher@leelanau.gov) to schedule an appointment time.

## 9.0 AWARD

- 9.01 The County reserves the right to make multiple awards with regard to this RFP if it is determined to be in the best interest of the County.
- 9.02 The County reserves the right to accept any submittal and/or parts thereof and/or to reject any or all submittals if it is determined to be in the best interests of the County.

## 10.0 SELECTION AND PROCUREMENT SCHEDULE

The County anticipates the following procurement schedule:

RFP Released.....September 5, 2024  
Site Visit ..... By appointment  
Questions Due to Administration .....September 17, 2024  
Questions Responses .....September 20, 2024  
Proposals Due .....September 24, 2024 at 3:00 p.m.  
Notice of Award ..... October 2, 2024 (Pending BOC Approval)  
Commence Work Date..... Contingent on any current State Order

## 11.0 CONTRACT TERM

- 11.01 The selected Proposer will be required to enter into a formal contract agreement with the County, which includes the contract terms set forth in Attachment B and insurance requirements set forth in Attachment E to this RFP.
- 11.02 The contract term will begin upon successful execution of the formal contract with the work being completed as described in section 2.0, Scope of Services.

## 12.0 QUESTIONS REGARDING PROPOSAL

- 12.01 For any questions pertaining to the RFP and its specifications, please submit them by email to Leelanau County Administration at [lcypher@leelanau.gov](mailto:lcypher@leelanau.gov) no later than the close of business on September 17, 2024. All answers to the submitted questions will be posted as an addendum on the following website on or before the close of business on September 20, 2024. <http://bidnetdirect.com>.

**PROPOSERS MUST CHECK THIS WEBSITE FOR ADDENDA BEFORE SUBMITTING THEIR PROPOSAL. ADDENDA MAY INCLUDE SIGNIFICANT CHANGES TO THE RFP.**

## 13.0 SUBMISSION

- 13.01 All proposals must include:
  - 13.01.1 Documentation to completely satisfy Sections 4.0 Proposal Submission including the Contractor Qualification Statement (See Attachment A).
  - 13.01.2 Completed and signed form CS-1 Proposal Form;
  - 13.01.3 Completed and signed form CS-2 Non-Collusion Affidavit;
  - 13.01.4 Signed Certificate of Compliance with State of Michigan Public Act 517 of 2012 (See Attachment D)
- 13.02 Proposers are required to submit one (1) original and one (1) copy of their proposal to:

**Administrator**

County of Leelanau

Leelanau County Government Center, Suite #101

Suttons Bay, Michigan 49682

Proposals must be sealed and clearly marked LCAO-RFP-2024-007 and received no later than **September 24, 2024, at 3:00 p.m.**



**COUNTY OF LEELANAU**

**PROPOSAL FORM**

The undersigned, having carefully examined the appropriate specifications, #LCAO-RFP-2024-007, dated \_\_\_\_\_, 2024, does hereby agree to furnish and deliver to the County of Leelanau, Suttons Bay, Michigan, the following items at the price(s) indicated:

Item #	SCHEDULE OF ITEMS	PRICE
1	Demolition and Disposal	
2	Decking, Ipe	
3	Railing & Guard	
4	Rail Posts, Ipe	
	Alternative #1: Replace Ipe wood with Thermally Modified Ash. Apply add/deduct to cost here	
	Alternative #2: Replace Ipe wood with Treated SYP. Apply add/deduct to cost here	
	Summation of Items 1-4	
	Summation of Items 1-4 with Thermally Modified Ash Alternative	
	Summation of Items 1-4 with Treated SYP Alternative	

**Submitted by**

(Company Name): \_\_\_\_\_

Address: \_\_\_\_\_

**Contact Name**

(Print): \_\_\_\_\_ Signature: \_\_\_\_\_

Telephone: \_\_\_\_\_ Fax: \_\_\_\_\_

Email: \_\_\_\_\_

**NOTE:** By signing and submitting this bid for consideration by the Leelanau County Administrator, the vendor acknowledges that they have read, understand and agree to all aspects of the specifications as presented without reservation or alteration.

**CS-1**

# Non-Collusion Affidavit

**Bid #LCAO-RFP-2024-007  
LELAND DAM PEDESTRIAN BRIDGE SURFACE  
AND RAILING REPLACEMENT PROJECT**

This Affidavit shall be submitted with and made part of this proposal to the County of Leelanau:

State of Michigan  
County of Leelanau

\_\_\_\_\_, being duly sworn, deposes and says that:

1. The proposal has been arrived at by the Proposer independently and has been submitted without collusion with, and without any agreement, understanding, or planned common course of action with any other vendor of materials, supplies, equipment, or services described in the RFP, designed to limit independent proposals or competition; and
2. The contents of the proposal have not been communicated by the Proposer or its employers or agents to any person not an employee or agent of the Proposer or its surety on any bond furnished with the proposal and will not be communicated to any such person prior to the official opening of the proposals.
3. The undersigned is duly authorized to execute this affidavit on behalf of the Proposer.

\_\_\_\_\_  
Authorized Signature

Subscribed and sworn to before me this

\_\_\_\_\_ day of \_\_\_\_\_, 20\_\_\_\_

\_\_\_\_\_  
Printed Name of Signatory

\_\_\_\_\_  
Company Name

\_\_\_\_\_  
, Notary Public

\_\_\_\_\_  
Address

My Commission expires: \_\_\_\_\_

\_\_\_\_\_  
City/State/Zip

\_\_\_\_\_  
Phone Number

**CS-2**

**ATTACHMENT "A" - Contractor's Qualification Statement**

**CONTRACTOR'S QUALIFICATION STATEMENT**

The undersigned certifies under oath that the information provided herein is true and sufficiently complete so as not to be misleading.

Submitted to: Leelanau County Administration  
Attention: Administrator

Submitted by: Firm Name: \_\_\_\_\_  
Address: \_\_\_\_\_  
Principal Office Location: \_\_\_\_\_

Submitted for: LELAND DAM PEDESTRIAN BRIDGE SURFACE AND RAILING REPLACEMENT PROJECT

**Organization:**

Provide the following information concerning your organization. Type of Entity:

Corporation \_\_\_\_\_  
Partnership \_\_\_\_\_  
Individual \_\_\_\_\_  
Other \_\_\_\_\_

**Names of Principal, Owners, or Partners**

<u>Name</u>	<u>Position</u>	<u>Years of Service with Organization</u>
_____	_____	_____
_____	_____	_____
_____	_____	_____
_____	_____	_____

Number of years this organization has been in business? \_\_\_\_\_  
\_\_\_\_\_

Have members of this organization operated under former names / businesses?

Yes \_\_\_\_\_ No \_\_\_\_\_

If "yes", list name, type of entity, and names of principal, owners, or partners:

\_\_\_\_\_  
\_\_\_\_\_

Provide four project examples of similar scope of work within the last five years. Provide back-up documentation.

1. \_\_\_\_\_ Year: \_\_\_\_\_
2. \_\_\_\_\_ Year: \_\_\_\_\_
3. \_\_\_\_\_ Year: \_\_\_\_\_
4. \_\_\_\_\_ Year: \_\_\_\_\_
5. \_\_\_\_\_ Year: \_\_\_\_\_

**Insurance and Bonds**

List names of current insurance carrier and number of your projects insured by carrier:

---

---

List names of bonding company / agent utilized for projects constructed during the last five years:

---

---

---

**Claims and Suites**

Has your organization ever failed to complete any construction work it has been Awarded?

Yes \_\_\_\_\_ No \_\_\_\_\_

Within the last five years, has any officer or principal of your organization ever been an officer or principal of another organization when it failed to complete a construction contract? (If the answer is yes, describe in full.)

Yes \_\_\_\_\_ No \_\_\_\_\_

Has there been in the last ten years, or is there now pending or threatened, any litigation, arbitration, investigation, or governmental or regulatory proceeding involving claims in excess of \$100,000 or requesting a declaratory judgment or injunctive relief with respect to the construction or operation of any building which your firm, its principals, predecessors, or affiliates constructed?

Yes \_\_\_\_\_ No \_\_\_\_\_

Are all city, county, state and federal taxes of any type, including real estate, FICA, and Workmen's Compensation paid to date?

Yes \_\_\_\_\_ No \_\_\_\_\_

Is there any potential arbitration, claim, demand, litigation, investigation, governmental proceeding, or regulatory proceeding involving your firm, its principals, predecessors, or affiliates? If the answer to either of the preceding questions is "Yes", describe in full in an attachment.

Yes \_\_\_\_\_ No \_\_\_\_\_

In addition to the litigation, arbitration, investigation, or governmental / regulatory proceeding referred to in the preceding paragraphs, is there any litigation, arbitration, investigation, or governmental / regulatory proceeding now pending or threatened to which your firm is or may be a party, or are you aware of any potential claim or demand, which might otherwise affect the capacity of your firm to perform with respect to your involvement with the Owner, whether or not it concerns other work which you have undertaken? If so, describe in full.

Yes \_\_\_\_\_ No \_\_\_\_\_

**Bankruptcy**

Has your firm, its principals, predecessors, or affiliates been the subject of any proceeding under federal bankruptcy laws or any other proceedings under state or federal law in which a court or government agency has assumed jurisdiction over any of the assets or business of your firm, its principals, predecessors, or affiliates? If so, identify the proceedings, the court or governmental body, and the date such jurisdiction was assumed in an attachment.

Yes \_\_\_\_\_ No \_\_\_\_\_

**Change Order History**

Describe each instance within the last five years where change orders applied for during construction amounted in the aggregate to more than five percent of the contract price for any building which your firm constructed, or in which actual construction costs exceeded the contract price by more than five percent in an attachment.

**References**

**1. Name of Business:** \_\_\_\_\_  
**Contact Name:** \_\_\_\_\_  
**Address:** \_\_\_\_\_  
**Amount of Contract:** \_\_\_\_\_ **Telephone Number:** \_\_\_\_\_  
**Email:** \_\_\_\_\_ **Fax Number:** \_\_\_\_\_  
**Type of Work:** \_\_\_\_\_

---

**2. Name of Business:** \_\_\_\_\_  
**Contact Name:** \_\_\_\_\_  
**Address:** \_\_\_\_\_  
**Amount of Contract:** \_\_\_\_\_ **Telephone Number:** \_\_\_\_\_  
**Email:** \_\_\_\_\_ **Fax Number:** \_\_\_\_\_  
**Type of Work:** \_\_\_\_\_

---

**3. Name of Business:** \_\_\_\_\_  
**Contact Name:** \_\_\_\_\_  
**Address:** \_\_\_\_\_  
**Amount of Contract:** \_\_\_\_\_ **Telephone Number:** \_\_\_\_\_  
**Email:** \_\_\_\_\_ **Fax Number:** \_\_\_\_\_

Type of Work: \_\_\_\_\_

---

4. Name of Business: \_\_\_\_\_

Contact Name: \_\_\_\_\_

Address: \_\_\_\_\_

Amount of Contract: \_\_\_\_\_ Telephone Number: \_\_\_\_\_

Email: \_\_\_\_\_ Fax Number: \_\_\_\_\_

Type of Work: \_\_\_\_\_

Company Name of Proposer: \_\_\_\_\_

By: \_\_\_\_\_ Title: \_\_\_\_\_

*Any alterations to this document made by the offeror may be grounds for rejection of the proposal, cancellation of any subsequent award, or any other legal remedies available to the County of Leelanau.*

**ATTACHMENT “B” – Sample Contract Agreement**

*\*This is a Sample Agreement. The attachments referenced in this Agreement are not included in this packet.\**

**AGREEMENT**

**THIS AGREEMENT**, is made and entered into this \_\_\_\_ day of \_\_\_\_\_, 2024, by and between the **COUNTY OF LEELANAU**, a municipal corporation and political subdivision of the State of Michigan (hereinafter referred to as the “County”) and \_\_\_\_\_, whose business address is \_\_\_\_\_ (hereinafter referred to as the “Contractor”).

**RECITALS:**

**WHEREAS**, the County requested proposals for Leland Dam Pedestrian Bridge Surface and Railing Replacement Project located at 109 River St, Leland, MI 49654 (hereinafter referred to as the “Project”); and

**WHEREAS**, the Contractor has submitted a proposal to the County to provide services relating to the project; and

**WHEREAS**, the County accepts the Contractor’s proposal subject to the terms and conditions of this Agreement.

**NOW, THEREFORE**, for and in consideration of the mutual covenants hereinafter contained, **IT IS HEREBY AGREED** as follows:

**I. SERVICES TO BE PERFORMED BY THE CONTRACTOR.** The Contractor shall provide services consistent with the Contractor’s Proposal. A copy of said Proposal is attached to this Agreement labeled Attachment A. The attached Attachment A is incorporated by reference into this Agreement and is made a part thereof.

The primary interface between the Contractor and the County shall be through the Leelanau County Administrator’s Office. The Leelanau County Administrator’s Office shall be responsible for the coordination of the Contractor’s work.

**II. COMPENSATION.** The County shall pay the Contractor as set forth in the fee schedule provided in the Proposal attached as Attachment A. The compensation authorized in this section may be billed by the Contractor after the completion of each of the tasks identified in the Proposal. The Contractor’s bills shall set forth a brief description of the services performed and products produced by it, the total sum due and such additional information as the County may require. It is understood and agreed that the Contractor shall not bill and the County shall not pay for the Project until after the Project has been completed, including all items on the Project’s final punch list.

The County shall process and pay the Contractor’s bills, pursuant to the County’s procedure for payment of Accounts Payable. It is expressly understood and agreed that the total sum which the County shall pay for the project under this Agreement shall not exceed the sum of \_\_\_\_\_.

**III. COUNTY'S RESPONSIBILITIES.** The County shall provide the following to assist the Contractor with the Project and its completion:

A.

B.

**IV. RECORD DOCUMENTS.** Upon completion of the work, the Contractor shall compile for and deliver to the County a reproducible set of Record Drawings based upon the marked-up record drawings, addenda, change orders and other data.

**V. ADDITIONAL SERVICES.** Additional services, not specifically identified in Section I. Scope of Services and the attached Exhibit A shall be paid for by the County in addition to the fees set forth in Section II of this Agreement provided the County and Contractor set forth their agreement with respect to such additional services, the costs therefore and the method for payment of such costs in a written amendment to this Agreement signed by the authorized representatives of both parties.

**VI. ABANDONMENT OF WORK.** If any work is abandoned or suspended, the Contractor shall be paid for services performed prior to receipt of written notice from the County of abandonment or suspension.

**VII. STANDARD OF CARE.** In providing services under this Agreement, the Contractor shall perform its services in a manner consistent with that degree of care and skill ordinarily exercised by members of the same profession currently practicing under similar circumstances. Failure to meet such standards shall be a material breach of this Agreement.

**VIII. APPLICABLE LAW AND VENUE.** This Agreement shall be subject to, governed by, and construed according to the laws of the State of Michigan. It is expressly understood and agreed that any legal or equitable action that arises out of or regarding this Agreement shall be in Michigan Courts whose jurisdiction and venue shall be established in accordance with the statutes of the State of Michigan and Michigan Court Rules. In the event any action is brought in or moved to Federal Court, the venue for such action shall be the Federal Judicial District of Michigan, Western District, Southern Division.

**IX. NONDISCRIMINATION.** The Contractor, as required by law, shall not discriminate against an employee or applicant for employment with respect to hire, tenure, terms, conditions or privileges of employment, or a matter directly or indirectly related to employment because of race, color, religion, national origin, age, sex, gender identification, gender expression, height, disability or genetic information which is unrelated to the individual's ability to perform the duties of a particular job or position, weight, marital status or political affiliation.

The Contractor shall adhere to all applicable Federal, State and local laws, ordinances, rules and regulations prohibiting discrimination, including, but not limited to the following: (i) the Elliott-Larsen Civil Rights Act, 1976 PA 453, as amended; (ii) the Persons with Disabilities Civil Rights Act, 1976 PA 220, as amended; (iii) Section 504 of the Federal Rehabilitation Act of 1973, P.L. 93-112, 87 Stat 355, as amended, and regulations adopted thereunder; and (iv) the Americans with Disabilities Act of 1990, P.L. 101-336, 104 Stat 327 (42 USC §12101 *et seq.*), as amended, and regulations promulgated thereunder.



Breach of this Section shall be regarded as a material breach of this Agreement.

**X. INDEPENDENT CONTRACTOR.**

- A. It is expressly understood and agreed that the Contractor, its subcontractors and sub-subcontractors, are independent contractors. The employees, servants, agents and assigns of the Contractor, its subcontractors or sub-subcontractors shall in no way be deemed to be and shall not hold themselves out as employees, servants or agents of the County and shall not be entitled to any fringe benefits of the County, such as, but not limited to, health and accident insurance, life insurance, paid vacation or sick leave, or longevity. The Contractor, its subcontractors and sub-subcontractors shall be responsible for paying all salaries, wages and other compensation which may be due their employees or agents for performing work under this Agreement and for the withholding and payment of all applicable taxes, including, but not limited to, income and social security taxes, to the proper Federal, State and local governments.
- B. The direction and supervision of the working forces, including subcontractors, rests exclusively with the Contractor. The County shall not issue any instructions to, or otherwise interfere with the same.

**XI. INDEMNIFICATION AND HOLD HARMLESS.** The Contractor shall, at its own expense, protect, defend, indemnify and hold harmless the County, and its elected and appointed officers, employees and agents from all claims, damages, costs, law suits and expenses, including, but not limited to, all costs from administrative proceedings, court costs and attorney fees that they may incur as a result of any acts, omissions or negligence of the Contractor or any of its officers, employees, agents or subcontractors which may arise out of this Agreement.

The Contractor's indemnification responsibilities under this section shall include the sum of damages, costs and expenses which are in excess of the sum paid out on behalf of or reimbursed to the County, its officers, employees and agents by the insurance coverage obtained and/or maintained by the Contractor pursuant to the requirements of this Agreement.

**XII. LIABILITY INSURANCE.** The Contractor at all times during the term of this Agreement shall maintain insurance that meets the requirements of Leelanau County's Board of Commissioners Policy on "Insurance Requirements." A copy of said Board Policy is attached to this Agreement labeled Attachment B. The attached Attachment B is incorporated by reference into this Agreement and is made a part thereof.

**XIII. WAIVERS.** No failure or delay on the part of either the County or the Contractor in exercising any right, power or privilege hereunder shall operate as a waiver thereof, nor shall a single or partial exercise of any right, power or privilege preclude any other or further exercise of any other right, power or privilege. No modification, amendment, or waiver of any provision of this Agreement, nor consent to any departure from any provision of the Agreement by either party hereto, shall in any event be effective unless the same is in writing and signed by the other party, and then such waiver or consent shall be effective only in the specific instance and for the purpose for which given.

In no event shall the making by the County of any payment due to the Contractor constitute or be construed as a waiver by the County of any breach of a provision of this Agreement, or any default which may then exist, on the part of the Contractor. The making of any such payment by the

County while any such breach or default shall exist, shall in no way impair or prejudice any right or remedy available to the County in respect to such breach or default.

**XIV. MODIFICATION OF AGREEMENT.** Modifications, amendments or waivers of any provisions of this Agreement may be made only by the written mutual consent of the parties hereto.

**XV. ASSIGNMENT OR SUBCONTRACTING.** The parties to this Agreement may not assign, subcontract or otherwise transfer their duties and/or obligations under this Agreement.

**XVI. PURPOSE OF SECTION TITLES.** The titles of the sections set forth in this Agreement are inserted for the convenience of reference only and shall be disregarded when construing or interpreting any of the provisions of this Agreement.

**XVII. COMPLETE AGREEMENT.** This Agreement, Attachment A and Attachment B contain all the terms and conditions agreed upon by the parties hereto, and no other agreements, oral or otherwise, regarding the subject matter of this Agreement or any part thereof shall have any validity or bind any of the parties hereto.

**XVIII. AGREEMENT PERIOD.** This Agreement shall become effective on the date in which it has been fully signed by the authorized representatives of both parties (hereinafter referred to as the “Effective Date”). All work on the Project including all items on the final punch list and Work Site clean-up shall be completed by no later than the \_\_\_\_ day of \_\_\_\_\_, 202\_\_ (hereinafter referred to as the “Completion Date”).

It is also understood and agreed by the parties hereto that all obligations of the Contractor set forth in this Agreement which extend to beyond the Completion Date of the work shall survive said completion and remain in full force and effect for the time set for the performance of said obligations.

Notwithstanding any other provision in this Agreement to the contrary, the County may terminate this Agreement, with or without cause, upon five (5) days prior written notice to the Contractor. In the event this Agreement is prematurely terminated without cause (i.e. for reasons other than Contractor’s breach of the terms of this Agreement) as set forth herein, the Contractor shall be compensated for services completed as of the effective date of termination in accordance with Section II of this Agreement.

**XIX. IRAN LINKED BUSINESS.** The Contractor has certified to the County that neither it nor any of its successors, parent companies, subsidiaries, or companies under common ownership or control of the Contractor, are an “Iran Linked Business” engaged in investment activities of \$20,000,000.00 or more with the energy sector of Iran, within the meaning of Michigan Public Act 517 of 2012. It is expressly understood and agreed that the Contractor shall not become an “Iran linked business” during the term of this Agreement.

**NOTE: IF A PERSON OR ENTITY FALSELY CERTIFIES THAT IT IS NOT AN IRAN LINKED BUSINESS AS DEFINED BY PUBLIC ACT 517 OF 2012, IT WILL BE RESPONSIBLE FOR CIVIL PENALTIES OF NOT MORE THAN \$250,000.00 OR TWO TIMES THE AMOUNT OF THE CONTRACT FOR WHICH THE FALSE CERTIFICATION WAS MADE, WHICHEVER IS GREATER, PLUS COSTS OF INVESTIGATION AND REASONABLE ATTORNEY FEES INCURRED, AS MORE FULLY SET FORTH IN SECTION 5 OF ACT NO. 517, PUBLIC ACTS OF 2012.**

**XX. SEVERABILITY OF INVALID PROVISIONS.** If any part of this Agreement is declared by any Court having jurisdiction to be invalid, unconstitutional, or beyond the authority of either party to enter into or carry out, such part shall be deemed deleted and shall not affect the validity of the remainder of this Agreement, which shall continue in full force and effect. If the removal of such provision would result in the illegality and/or unenforceability of this Agreement, this Agreement shall terminate as of the date in which the provision was found invalid, unconstitutional or beyond the authority of the parties and the Contractor shall be reimbursed for all services which it has provided under this Agreement up to the date of termination.

**XXI. CERTIFICATION OF AUTHORITY TO SIGN AGREEMENT.** The people signing this Agreement on behalf of the parties hereto certify by their signatures that they are duly authorized to sign on behalf of said parties and that this Agreement has been authorized by said parties.

**THE AUTHORIZED REPRESENTATIVES OF THE PARTIES HERETO HAVE FULLY EXECUTED THIS AGREEMENT FOR THE ASPHALT REPAIR SEALCOATING, AND STRIPING OF THE LEELANAU COUNTY GOVERNMENT CENTER CAMPUS.**

**COUNTY OF LEELANAU**

\_\_\_\_\_

By: \_\_\_\_\_  
Ty Wessell, Chairman  
County Board of Commissioners

By: \_\_\_\_\_  
(Signature)

Name: \_\_\_\_\_  
(Print or Type)

Date: \_\_\_\_\_

Title: \_\_\_\_\_  
(Print or Type)

Date: \_\_\_\_\_

## ATTACHMENT "C" – Work Item Descriptions

### **Intent:**

It is the intent of Leelanau County to contract with one vendor for the removal and replacement of the existing wood decking and railing system of the Leland Dam pedestrian bridge, located at 109 W River St, Leland, MI 49654, as assigned by the County Administrator.

The following work items shall be in accordance with the plans, specifications and in accordance with the following:

1. **DEMOLITION AND DISPOSAL**

This item shall include the complete removal and disposal of the existing decking, railing, and rail posts and shall include the furnishing of all transportation, equipment/tools, labor, and all other work necessary to provide for the Demolition and Disposal as outlined in the project documents. Provide all necessary site security, fencing as necessary, to protect the work site from the public and workers. All permitting and notifications to local businesses is included in this work item. Measured and paid for on a lump sum basis (LS).

2. **DECKING, IPE**

This item shall include the furnishing of all materials, labor, equipment/tools, material submittals for review and approval by Engineer, installation, and all materials and fasteners necessary for the complete installation of the decking system. Wood species to be Ipe. Measured and paid for by the lump sum (LS).

3. **RAILING & GUARD, IPE**

This item shall include the furnishing of fabrication, all equipment/tools, labor, material submittal for review and approval by Engineer, work by certified welders, galvanizing, erection, wood rails to match decking, and all other components necessary to furnish a complete and installed railing system. Wood species to be Ipe. Measured and paid for by the lump sum (LS).

4. **RAIL POSTS, IPE**

This item shall include the furnishing of fabrication, all equipment/tools, labor, material submittal for review and approval by Engineer, wood rail posts to match decking, and all other components necessary to furnish a complete and installed railing system. Wood species to be Ipe. Measured and paid for by the lump sum (LS).

### **Alternative Bid Items:**

5. **ALTERNATIVE MATERIAL 1:**

Replace base material Ipe for Thermally Modified Ash in this alternative. Work item description remains same as base material.

6. **ALTERNATIVE MATERIAL 2:**

Replace base material Ipe for Treated Southern Yellow Pine (SYP #2) in this alternative. Work item description remains same as base material.

**ATTACHMENT “D” – CERTIFICATE OF COMPLIANCE  
WITH PUBLIC ACT 517 OF 2012**

*(Please type or print clearly in ink only)*

I certify that neither \_\_\_\_\_ (Company), nor any of its successors, parent companies, subsidiaries, or companies under common control, is an “Iran Linked Business” engaged in investment activities of \$20,000,000.00 or more with the energy sector of Iran, within the meaning of Michigan Public Act 517 of 2012. In the event it is awarded a Contract as a result of this solicitation, Company will not become an “Iran linked business” during the course of performing the work under the Contract.

NOTE: IF A PERSON OR ENTITY FALSELY CERTIFIES THAT IT IS NOT AN IRAN LINKED BUSINESS AS DEFINED BY PUBLIC ACT 517 OF 2012, IT WILL BE RESPONSIBLE FOR CIVIL PENALTIES OF NOT MORE THAN \$250,000.00 OR TWO TIMES THE AMOUNT OF THE CONTRACT FOR WHICH THE FALSE CERTIFICATION WAS MADE, WHICHEVER IS GREATER, PLUS COSTS AND REASONABLE ATTORNEY FEES INCURRED, AS MORE FULLY SET FORTH IN SECTION 5 OF ACT NO. 517, PUBLIC ACTS OF 2012.

\_\_\_\_\_  
*(Name of Company)*

By: \_\_\_\_\_

Date: \_\_\_\_\_

Title: \_\_\_\_\_

## Attachment "E" – Leelanau County Board Policy on Insurance Requirements

GENERAL SUBJECT:	Administration/General (County Administrator)	Policy No.	<b>13</b>
SPECIFIC SUBJECT:	Insurance Requirements Policy	Adopted:	04/17/1990
		Revised:	02/15/1994
		Revised:	05/21/2013
		Revised:	12/19/2017

---

APPLIES TO: All Leelanau County Employees and Elected Officials.

---

**PURPOSE:** The Leelanau County Board of Commissioners hereby establishes a policy on insurance requirements for contractors, vendors, individuals, and/or organizations receiving monies from Leelanau County. The purpose of these requirements is to assure that the parties referenced above are accepting appropriate responsibility for insuring their own operations, and that they are not unduly exposing Leelanau County taxpayers to liability and/or loss.

The Contractor, and any and all of their subcontractors, shall not commence any work until they have met the insurance requirements outlined in this policy. All coverage shall be with insurance companies licensed and admitted to do business in the State of Michigan. All coverages shall be with insurance carriers acceptable to Leelanau County and have a minimum A.M. Best Company ([www.ambest.com](http://www.ambest.com)) Insurance Report rating of not less than A or A- (Excellent).

1. Workers' Compensation Insurance: The Contractor shall procure and maintain during the life of the contract, Workers' Compensation Insurance, including Employers' Liability Coverage, in accordance with all applicable statutes of the State of Michigan. Workers' Compensation and Employers' Liability Insurance are required if the party hires one or more persons or currently has employees. If a party currently does not have any employees, and is a sole proprietor, an affidavit must be filed with the County Clerk stating that the party currently has no employees and will not hire any while working for Leelanau County as a contractor or a subcontractor, etc. If a party currently does not have any employees and is incorporated (Inc.) or a limited liability corporation (LLC), they must file a Notice of Exclusion, WC-337, with the State of Michigan and then provide a copy of the State-approved document to the County Clerk.

2. Contractor's Tools & Equipment: The Contractor shall be responsible for insuring all its tools, equipment and materials which it may leave at the Project's work site. The County shall not be responsible for any loss or damage to the Contractor's tools, equipment and materials.
3. Professional Liability (Errors and Omissions) Insurance: [For contracts for professional services, e.g., Contractor, Engineers, Doctors, Dentist, etc.] The Contractor shall possess Professional Liability Insurance (errors and omissions) with limits of not less than \$1,000,000.00 per occurrence or claim. If the Professional Liability Insurance is on a claims-made basis, the Contractor shall purchase extended reporting period "tail" coverage for a minimum of three (3) years after termination of the Agreement.
4. Commercial General Liability Insurance: The Contractor shall procure and maintain during the life of their contract, Commercial General Liability Insurance on an "Occurrence Basis" with limits of liability not less than \$1,000,000.00 per occurrence and aggregate combined single limit, Personal Injury, Bodily Injury, and Property Damage. Coverage shall include the following extensions: (A) Contractual Liability; (B) Products and Completed Operations; (C) Independent Contractors Coverage; (D) Broad Form General Liability Extensions or equivalent; (E) Deletion of all Explosion, Collapse, and Underground (XCU) Exclusions, if applicable.
5. Motor Vehicle Liability: The Contractor shall procure and maintain during the life of their contract Motor Vehicle Liability Insurance, including Michigan No-Fault Coverage, with limits of liability not less than \$1,000,000.00 per occurrence combined single limit, Bodily Injury, and Property Damage. Coverage shall include all owned vehicles, all non- owned vehicles, and all hired vehicles.
6. Deductibles: The Contractor shall be responsible for paying all deductibles in its insurance coverages.
7. Additional Insured: Commercial General Liability and Motor Vehicle Liability Insurance, as described above, shall include an endorsement stating that the following shall be **Additional Insureds**: Leelanau County, all elected and appointed officials, all employees and volunteers, all boards, commissions, and/or authorities and board members, including employees and volunteers thereof. The Contractor's insurance coverages shall be primary to the Additional Insureds and not contributing with any other insurance or similar protection available to the Additional Insureds, regardless of whether said other available coverage be primary, contributing or excess.
8. Cancellation Notice: Workers' Compensation Insurance, Commercial General Liability Insurance, and Motor Vehicle Liability Insurance, as described above, shall include an endorsement stating the following: "It is understood and agreed that Thirty (30) days Advance Written Notice of Cancellation, Non-Renewal, Reduction, and/or Material Change shall be sent to the office of the Leelanau County Administrator.

9. Owners' and Contractors' Protective Liability: [For Contracts for Construction or Large Repair or Maintenance Projects such as road work, sewer work or building projects] The Contractor shall procure and maintain during the life of the contract, a separate Owners' and Contractors' Protective Liability Policy with limits of liability not less than \$1,000,000.00 per occurrence and aggregate combined single limit, Personal Injury, Bodily Injury, and Property Damage. Leelanau County shall be "Named Insured" on said coverage. Thirty (30) day Notice of Cancellation shall apply to this policy.
  
10. Proof of Insurance Coverage: The Contractor shall provide Leelanau County at the time that the contracts are returned by him/her for execution, A "Certificate of Liability Insurance," on Accord Form #25, with the necessary coverages included, as listed below:
  - a. Certificate of Insurance for Workers' Compensation Insurance;
  - b. Certificate of Insurance for Commercial General Liability Insurance;
  - c. Certificate of Insurance for Vehicle Liability Insurance;
  - d. Certificate of Insurance for Professional Liability Insurance on Projects where such insurance is required.
  - e. Original Policy, or original Binder pending issuance of policy, for Owners' & Contractors' Protective Liability Insurance, where such insurance is required.
  - f. If so requested, Certified Copies of all policies mentioned above will be furnished.
  
11. If any of the above coverages expire during the term of the contract, the Contractor shall deliver renewal certificates and/or policies to the Leelanau County Administrator at least ten (10) days prior to the expiration date.

Failure to comply with these insurance requirements could result in the termination of a contract or delay in receipt of funds. Questions regarding the scope of applicability of this policy may be directed to the Leelanau County Administrator.



**SPECIFICATIONS**

**DIVISION 01 – GENERAL NOTES**

**DESIGN**

- BUILDING CODE – THE MICHIGAN CODE (MIBC), 2015.
- THE DECKING AND RAILING WAS DESIGNED FOR ALL APPLICABLE DEAD LOADS AND THE FOLLOWING LIVE DESIGN LIVE LOADS:

DECK DEAD LOAD = 10 PSF

LIVE LOAD:

BRIDGE DECK = 90 PSF  
RAILING = 200 LBS AT ANY POINT ALONG RAIL OR 50 PLF ALONG RAILING

SNOW LOAD:

GROUND SNOW LOAD (Pg) = 60 PSF  
FLAT ROOF SNOW LOAD (Pf) = 55 PSF  
EXPOSURE FACTOR (Ce) = 1.1 (EXPOSURE 'C')  
TEMPERATURE FACTOR (Cl) = 1.2  
IMPORTANCE FACTOR (I) = 1.0

WIND LOAD (LATERAL-MFWRS):

BASIC WIND SPEED (V) = 115 MPH  
DIRECTIONAL FACTOR (Kd) = 0.85  
IMPORTANCE FACTOR (I) = 1.0  
INTERNAL PRESSURE COEFF = ±0.18  
WIND EXPOSURE = C

**GENERAL**

- THE CONTRACTOR IS TO PERFORM A PRE-BID INSPECTION OF THE CURRENT CONDITION TO VERIFY THE EXISTING STRUCTURE AGAINST THE WORK PROPOSED IN THESE PLANS.
- FASTENING OF THE WOOD SLEEPER IS UNKNOWN AND SHALL BE VERIFIED BY THE CONTRACTOR AND PROVIDED TO ENGINEER AFTER DEMOLITION IS COMPLETED AND PRIOR TO STARTING THE NEW CONSTRUCTION.
- CONTRACTOR IS TO PERFORM A COMPLETE FIELD VERIFICATION OF CONSTRUCTION PRIOR TO FABRICATING STEEL RAIL SECTIONS. DISCREPANCIES MADE IN FABRICATION THAT DIFFER FROM THE DETAILS PROVIDED IN THESE PLANS SHALL BE REPAIRED OR REPLACED TO THE SATISFACTION OF THE OWNER WITH COSTS INCLUDED IN THE COST OF THE WORK.
- ANY DISCREPANCIES OR CONFLICT BETWEEN ANY PART OF THE DESIGN DOCUMENTS, OR BETWEEN THE DESIGN DOCUMENTS AND APPLICABLE CODES, LAWS, OR ORDINANCES, SHALL BE BROUGHT TO THE ATTENTION OF THE ENGINEER, AND THE MORE STRINGENT REQUIREMENTS SHALL GOVERN.
- THE CONTRACTOR SHALL BE RESPONSIBLE FOR MEANS, METHODS, SEQUENCES, AND PROCEDURES OF CONSTRUCTION.
- NO CHANGE IN SIZE OF DIMENSION OF STRUCTURAL MEMBERS SHALL BE MADE WITHOUT THE WRITTEN APPROVAL OF THE ENGINEER.
- THE STRUCTURE IS DESIGNED TO FUNCTION AS A UNIT UPON COMPLETION. THE CONTRACTOR IS RESPONSIBLE FOR FURNISHING ALL TEMPORARY BRACING AND / OR SUPPORT THAT MAY BE REQUIRED AS THE RESULT OF THE CONTRACTOR'S CONSTRUCTION METHODS AND / OR SEQUENCES. PERMANENT BRACING IS TO BE COORDINATED WITH THE EXISTING BUILDING AND ITS COMPONENTS.
- DO NOT SCALE THESE DRAWINGS. USE DIMENSIONS. DIMENSIONS SHOWN ON STRUCTURAL DRAWINGS ARE FOR REFERENCE ONLY. CONTRACTOR SHALL VERIFY ALL DIMENSIONS WITH ARCHITECTURAL DRAWINGS AND PRE-ENGINEERED DRAWINGS.
- THE CONTRACTOR SHALL INFORM THE ENGINEER IN WRITING OF ANY DEVIATION FROM THE CONTRACT DOCUMENTS. THE CONTRACTOR SHALL NOT BE RELIEVED OF THE RESPONSIBILITY FOR SUCH DEVIATION BY THE ENGINEER'S APPROVAL OF SHOP DRAWINGS, PRODUCT DATA, ETC., UNLESS THE CONTRACTOR HAS SPECIFICALLY INFORMED THE ENGINEER OF SUCH DEVIATION AT THE TIME OF SUBMISSION, AND THE ENGINEER HAS GIVEN WRITTEN APPROVAL TO THE SPECIFIC DEVIATION.
- CONSTRUCTION SHALL COMPLY FULLY WITH THE APPLICABLE PROVISIONS OF OSHA AND THE LOCAL GOVERNING CODES, CURRENT EDITION, AND ALL REQUIREMENTS SPECIFIED IN THE CODES SHALL BE ADHERED TO AS IF THEY WERE CALLED FOR OR SHOWN ON THE DRAWINGS. THIS SHALL NOT BE CONSTRUED TO MEAN THAT REQUIREMENTS SET FORTH ON THE DRAWING MAY BE MODIFIED BECAUSE THEY ARE MORE STRINGENT THAN THE CODE REQUIREMENTS OR BECAUSE THEY ARE NOT SPECIFICALLY REQUIRED BY CODE.
- PRIOR TO CONSTRUCTION, THERE SHALL BE A COORDINATION MEETING BETWEEN THE OWNER AND CONTRACTOR ON SITE.
- THE CONTRACTOR SHALL MEET WITH AND COORDINATE ALL WORK WITH THE NEIGHBORING BUSINESSES WHO'S CUSTOMERS USE THE BRIDGE INCLUDING, BUT NOT NECESSARILY LIMITED TO, THE COVER RESTAURANT, AND FALLING WATERS LODGE. COSTS FOR THIS COORDINATION SHALL BE INCLUDED IN THE COST OF THE PROJECT.

**SPECIFICATIONS (CONTINUED)**

**DIVISION 05 – METALS**

**STRUCTURAL STEEL**

- MATERIALS SHALL CONFORM TO THE FOLLOWING STANDARDS:
  - ANGLES, PLATES, BASES: ASTM A36
- ALL STEEL SHALL BE HOT-DIPPED GALVANIZED. FABRICATOR SHALL PROVIDE VENT AND DRAIN HOLES WHERE REQUIRED BY GALVEMITER.
- IF REQUIRED, FIELD MODIFICATION OF HOT-DIPPED GALVANIZED COMPONENTS SHALL BE PREPARED AND COATED PER THE FOLLOWING IN ACCORDANCE WITH ASTM A780 'STANDARD PRACTICE FOR REPAIR OF DAMAGED AND UNCOATED AREAS OF HOT-DIP GALVANIZED COATING':
  - GRIND ALL CUT SURFACES TO A SEMI-SMOOTH APPEARANCE SIMILAR TO THE ORIGINAL PLATE EDGE FROM THE MANUFACTURER.
  - PREPARE SURFACES IN ACCORDANCE WITH SSPC-SP11 OR HAND TOOL AREAS IN ACCORDANCE WITH SSPC-SP2.
  - COATING MUST CONTAIN ZINC DUST.
  - COMPLETE A MINIMUM OF TWO SEPARATE HAND APPLIED COATINGS OF 0.002" PER COAT FOR A TOTAL OF 0.004".
- BOLT CONNECTIONS:
  - ALL BOLTED CONNECTIONS SHALL BE BEARING TYPE USING STAINLESS STEEL BOLTS.
  - OVERSIZED HOLES & LONG-SLOTTED HOLES ARE NOT ALLOWED UNLESS INDICATED ON THE DRAWINGS.
  - ALL BOLTS SHALL BE SNUG TIGHT.
- WELDED CONNECTIONS:
  - ALL WELDING SHALL BE IN ACCORDANCE WITH THE 'STRUCTURAL WELDING CODE' AWS D1.1 (LATEST EDITION) PUBLISHED BY THE AMERICAN WELDING SOCIETY.
  - ELECTRODES FOR WELDING SHALL CONFORM TO THE E-70 SERIES OF THE SPECIFICATION FOR MILD STEEL ARC WELDING ELECTRODES, LATEST EDITION.
  - ALL WELDING SHALL BE DONE BY CERTIFIED WELDERS.
- NO FINAL BOLTING OR WELDING SHALL BE MADE UNTIL AS MUCH OF THE STRUCTURE AS WILL BE STIFFENED THEREBY HAS BEEN PROPERLY ALIGNED.
- CONTRACTOR SHALL VERIFY ALL DIMENSIONS PRIOR TO FABRICATION. THE ENGINEER SHALL BE NOTIFIED IMMEDIATELY OF ANY DISCREPANCIES BETWEEN THE DESIGN AND ACTUAL FIELD CONDITIONS.

**DIVISION 06 – WOOD**

**LUMBER**

- WOOD REQUIREMENTS FOR VARIOUS USES SHALL BE AS FOLLOWS:
  - FRAMING LUMBER: NO. 2 AND BETTER SYP, TREATMENT RATING GROUND CONTACT.
  - WOOD BEAM:
    - SOUTHERN YELLOW PINE (SYP) #2: \_\_\_\_\_ E=1,400 PSI, Fb=1,100 PSI
- ALL WORK SHALL BE CUT AND FITTED AS NECESSARY BY CONDITIONS ENCOUNTERED AND SHALL BE PLUMBED, LEVELED, AND BRACED WITH SUFFICIENT NAILS, SPIKES, BOLTS, AND OTHER FASTENERS TO ENSURE RIGIDITY.
- WASHERS SHALL BE USED IN CONTACT WITH ALL BOLT HEADS AND NUTS THAT WOULD OTHERWISE BE IN CONTACT WITH WOOD.
- CONNECTORS, HANGERS, AND STRAP TIES ARE TO BE HOT-DIPPED GALVANIZED AND INSTALLED PER MANUFACTURER'S RECOMMENDATIONS.
- ALL FASTENERS TO BE STAINLESS STEEL (SS) BOLTS, BUTS, AND WASHERS.
- WOOD SPECIES FOR DECKING AND RAILING TO BE BASE BID IPE WITH ALTERNATIVE THERMALLY MODIFIED ASH AND TREATED SYP.

**Attachment "F"**



1235 E FRONT ST, Suite A  
TRAVERSE CITY, MI PH 231.935.1530  
www.machinengineering.net

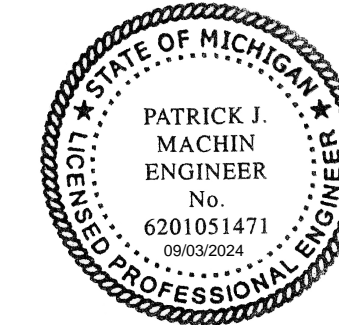

ON 22x34 SHEET SCALE: FULL (AS NOTED)  
ON 11x17 SHEET SCALE: HALF

REV#	DESCRIPTION	DATE
A	REVIEW - 30% DESIGN	04/09/2024
B	ISSUED FOR REVIEW	05/08/2024
C	ISSUED FOR BIDS	04/09/2024

DRAWN BY: E.S.	CHECK BY: F.M.	APPROVED BY: F.M.	CREATED: 09/03/2024
----------------	----------------	-------------------	---------------------

REVISION . . . . .

DATE . . . . . 09/03/2024

ISSUE . . . . .

PHASE: . . . . . BIDS

PROJECT TITLE:

LELAND DAM  
PEDESTRIAN BRIDGE  
DECK & RAILING  
UPGRADES

CLIENT:

PROJECT LOCATION:

LEELANAU COUNTY, MI

SHEET TITLE:

NOTES  
&  
SPECIFICATIONS

PROJECT NUMBER

24132

SHEET NUMBER

R1

REMOVE EXISTING SIGN SUPPORT FROM BRIDGE RAILING. SIGN TO BE REMOVED BY LODGE PROPERTY OWNER

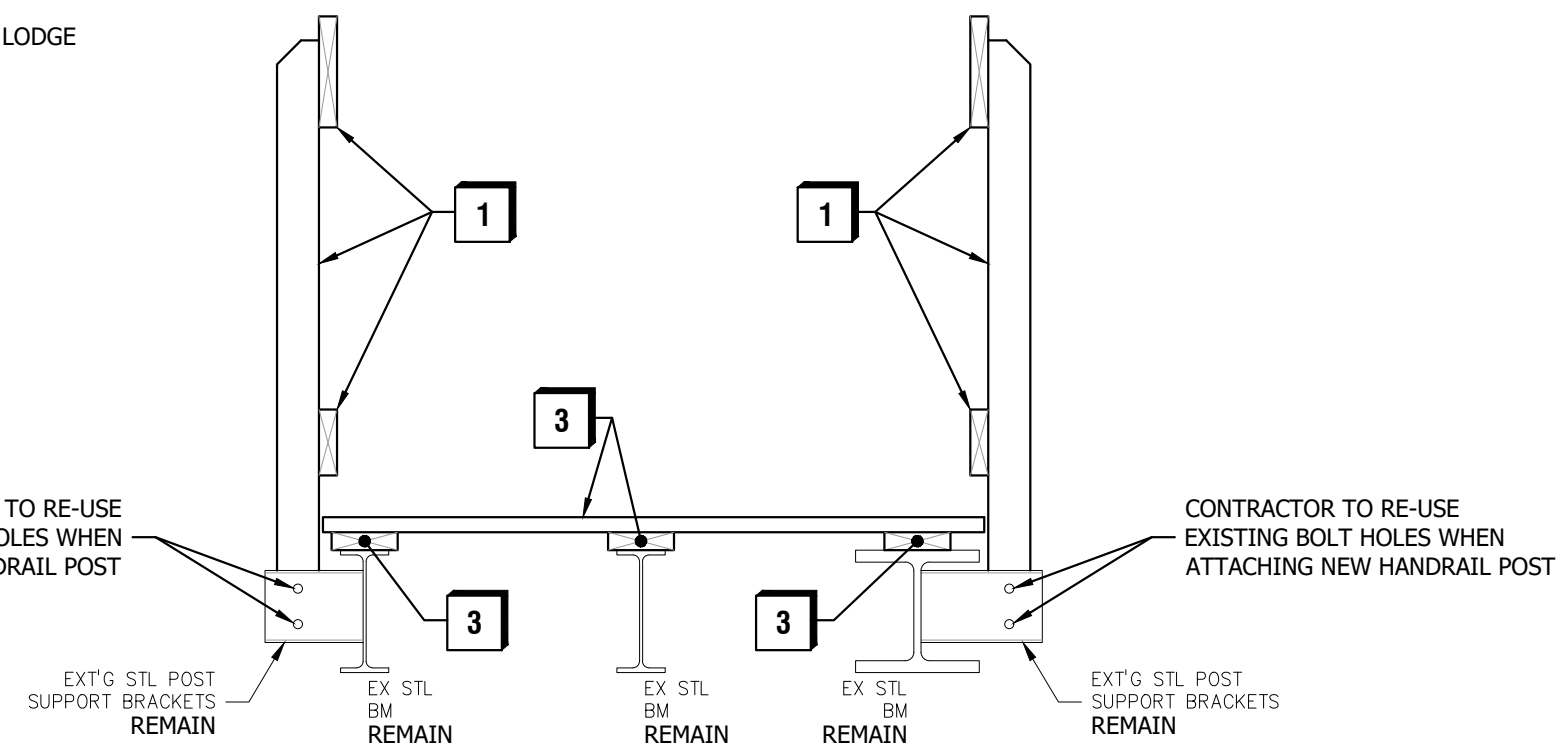

PHOTO 1



PHOTO 2

REMOVE EXISTING SIGN SUPPORT FROM BRIDGE RAILING. SIGN TO BE REMOVED BY LODGE PROPERTY OWNER



TYPICAL EXISTING BRIDGE CROSS-SECTION

SCALE: 3/4"=1'-0"

KEY NOTES	
1	REMOVE EXISTING WOOD RAILING & POST
2	REMOVE EXISTING WOOD GATE
3	REMOVE EXISTING WOOD DECKING AND EXISTING WOOD SLEEPERS
4	REMOVE EXISTING WOOD RAILING & POST, EXT'G POST BASE CAP TO REMAIN IN PLACE

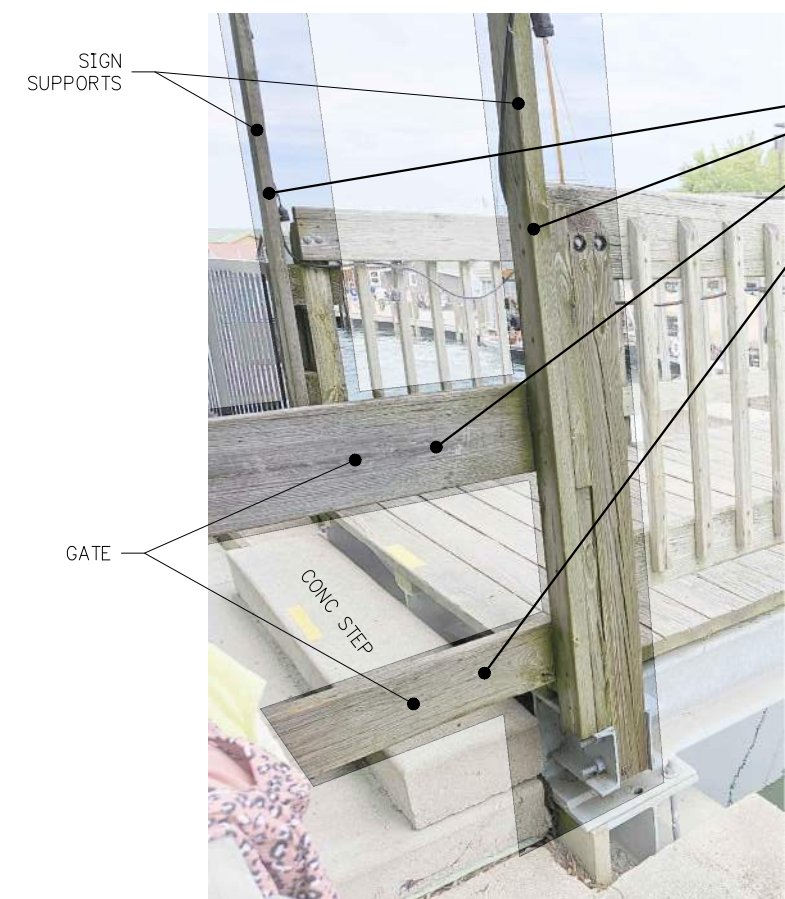
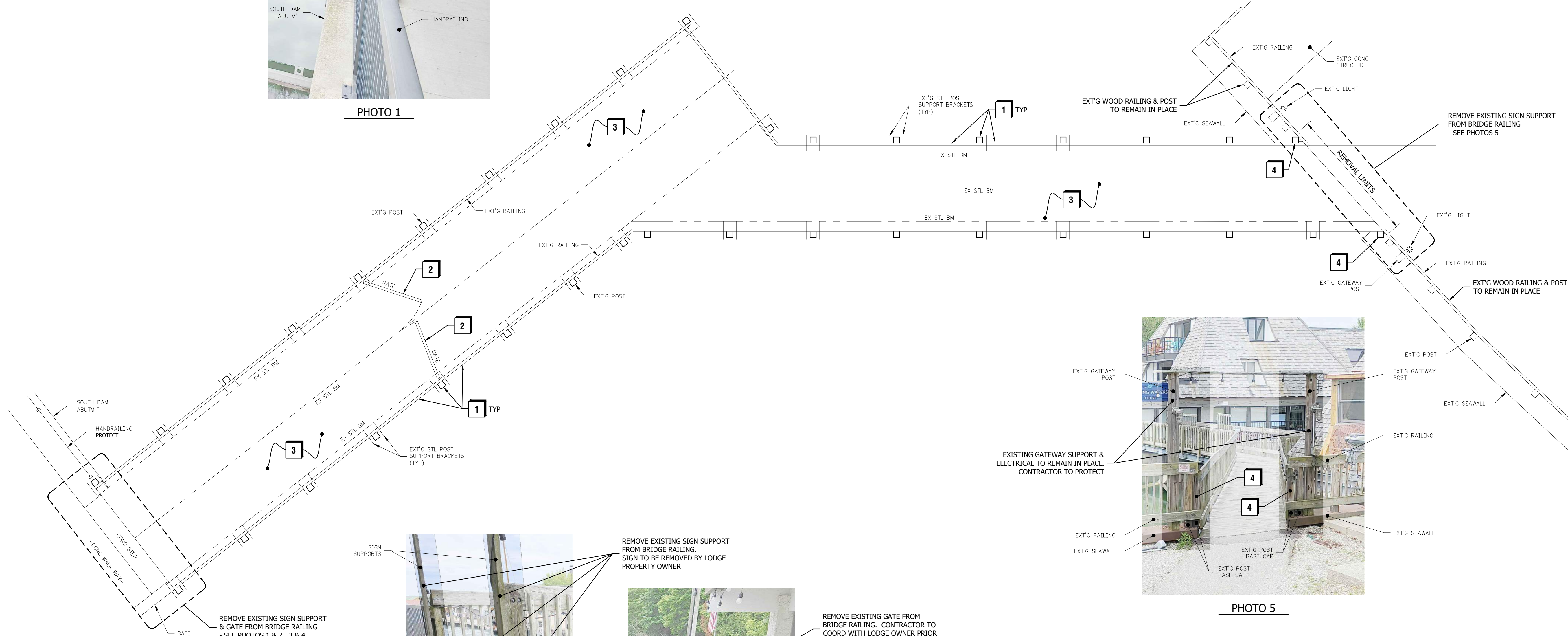

PHOTO 3



PHOTO 4

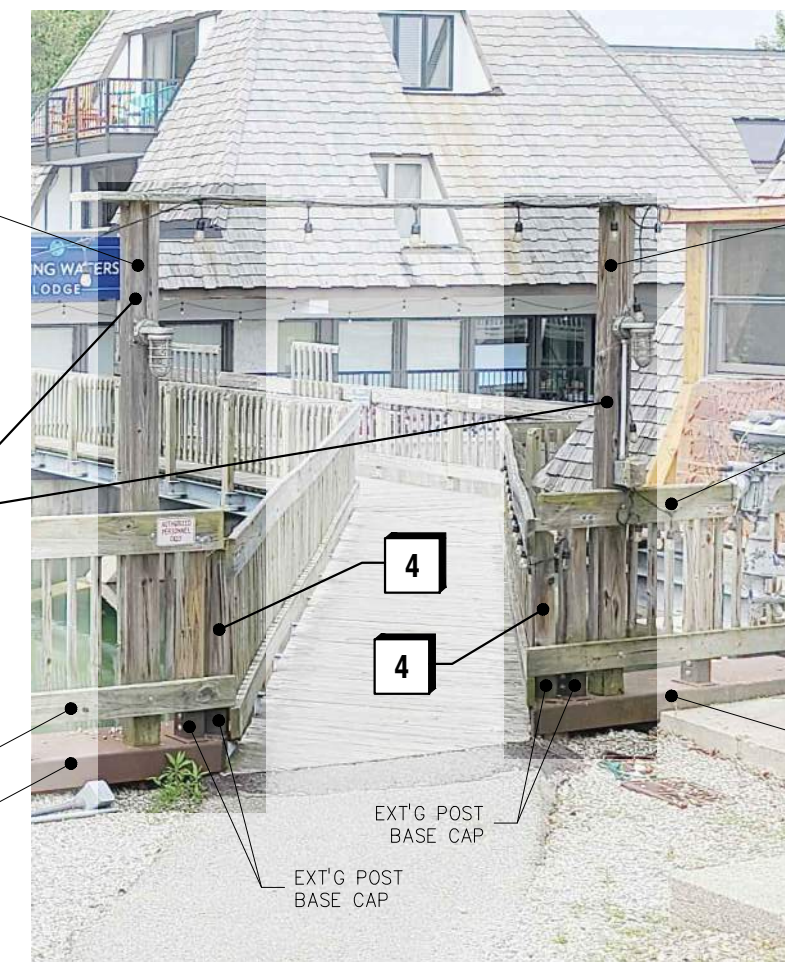
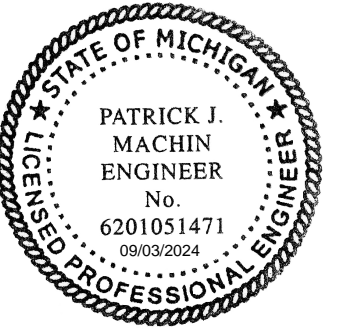

PHOTO 5



ON 22x34 SHEET SCALE: FULL (AS NOTED)  
 ON 11x17 SHEET SCALE: HALF

REV#	DESCRIPTION	DATE
A	REVIEW 30% DESIGN	04/08/2024
B	ISSUED FOR REVIEW	05/08/2024
C	ISSUED FOR BIDS	04/08/2024

DESIGNED BY:	CHKD BY:	APPROVED BY:	CREATED:
J.S.	F.M.	F.M.	08/15/2024

REVISION: .  
 DATE ISSUED: 09/03/2024  
 ISSUE PHASE: BIDS

PROJECT TITLE:  
**LELAND DAM  
 PEDESTRIAN BRIDGE  
 DECK & RAILING  
 UPGRADES**

CLIENT:  
 PROJECT LOCATION:  
**LEELANAU COUNTY, MI**

SHEET TITLE:  
**EXISTING  
 SITE CONDITIONS  
 &  
 DEMOLITION PLAN**

PROJECT NUMBER: **24132**  
 SHEET NUMBER: **S1**

- KEY NOTES**
- 1 PROPOSED TRTD WOOD POST & DECORATIVE SPINDLE - SEE TYPICAL DETAIL
  - 2 PROPOSED TRTD WOOD DECKING AND TRTD WOOD SLEEPERS
  - 3 PROPOSED TRTD WOOD POST, ATTACHED TO EXTG POST BASE CAP
  - 4 PROPOSED CUSTOM RAILING PANEL

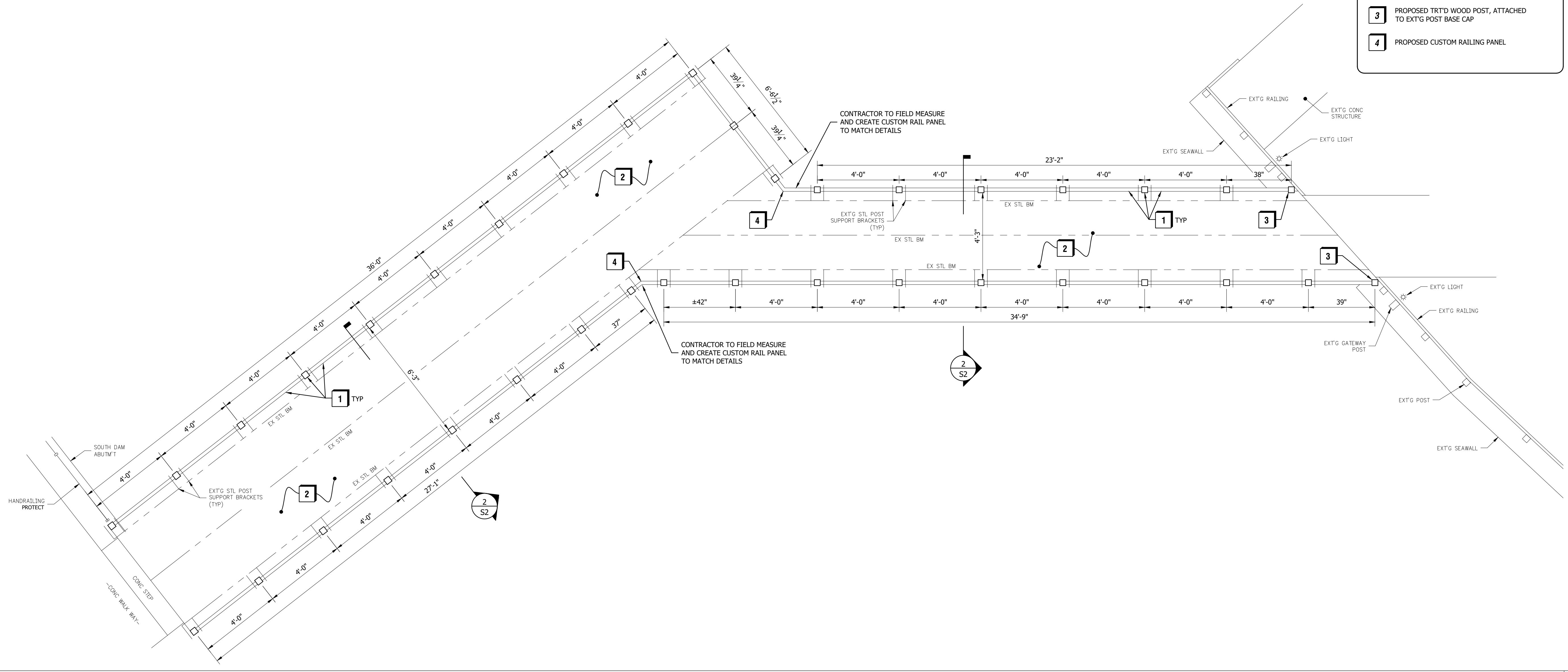

ON 22x34 SHEET SCALE: FULL (AS NOTED)  
 ON 11x17 SHEET SCALE: HALF

REV#	DESCRIPTION	DATE
A	REVIEW - 30% DESIGN	KAS00724
B	ISSUED FOR REVIEW	5/08/2024
C	ISSUED FOR BIDS	KAS00024

PROPOSED BRIDGE STRUCTURE PLAN 3/8"=1'-0" 1

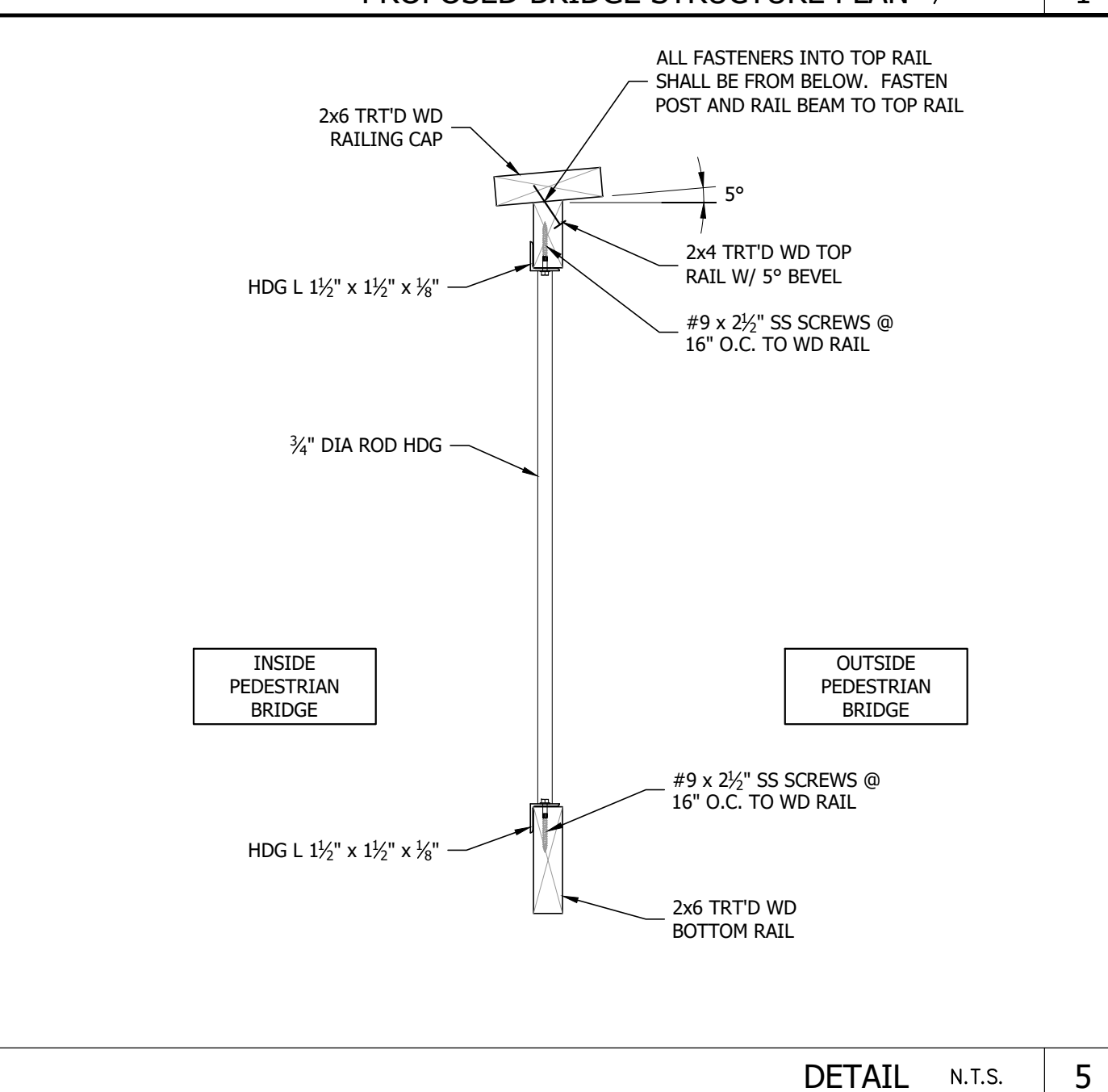
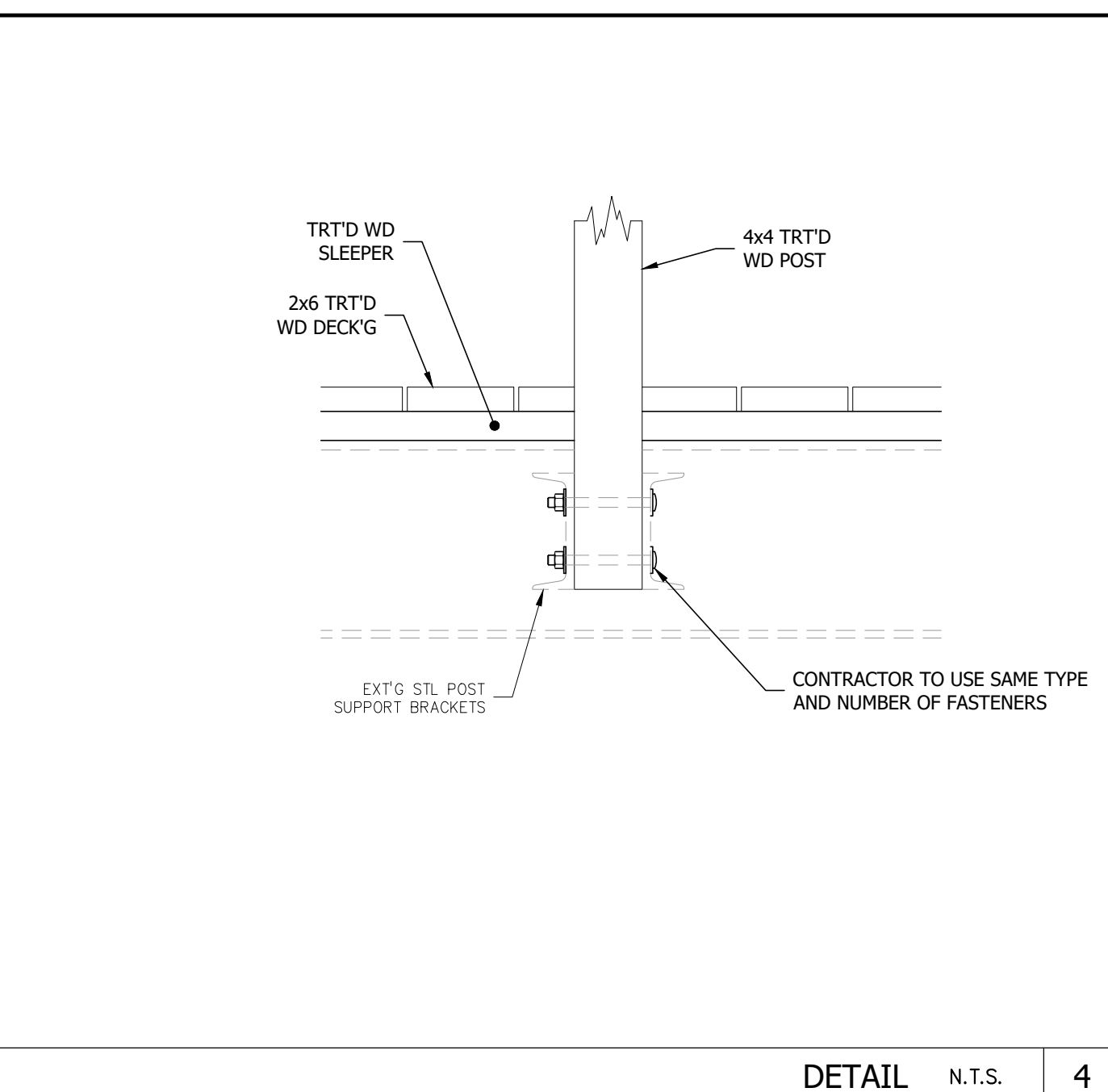
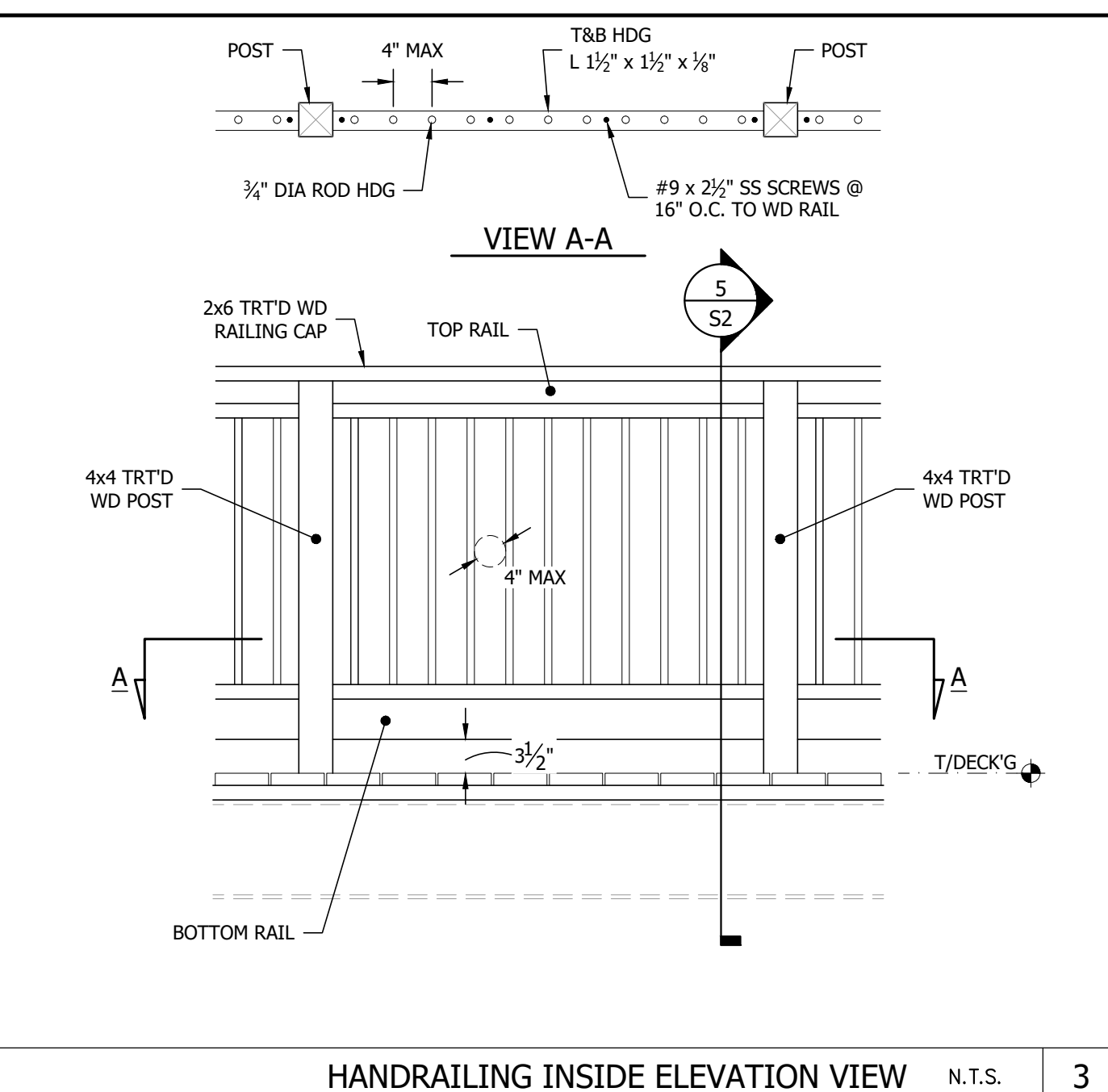
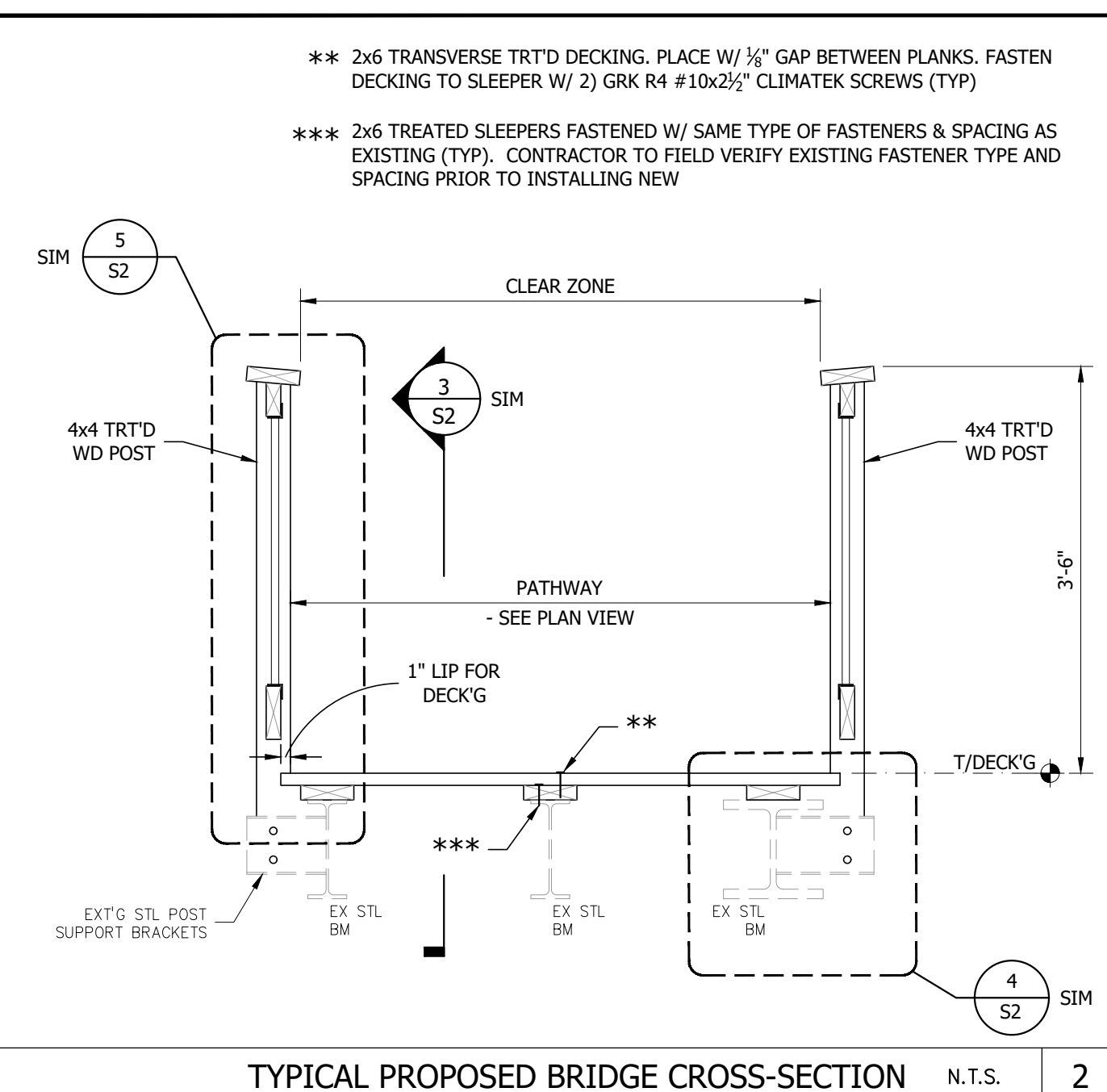

REVISION

DATE ISSUED: 09/03/2024

ISSUE PHASE: BIDS

PROJECT TITLE: **LELAND DAM PEDESTRIAN BRIDGE DECK & RAILING UPGRADES**

CLIENT:

PROJECT LOCATION: **LEELANAU COUNTY, MI**

SHEET TITLE: **PROPOSED PEDESTRIAN BRIDGE DECK LAYOUT & DETAILS**

PROJECT NUMBER: **24132**

SHEET NUMBER: **S2**

C:\USERS\KURTSCHE\APPDATA\LOCAL\TEMP\ASPHIL134\_26560\24132\_STR\_DECK.DWG (09-03-24 11:10 PM) KURTSCHE